

Cortadora CUTLASS 400 (M)



Fig. 1

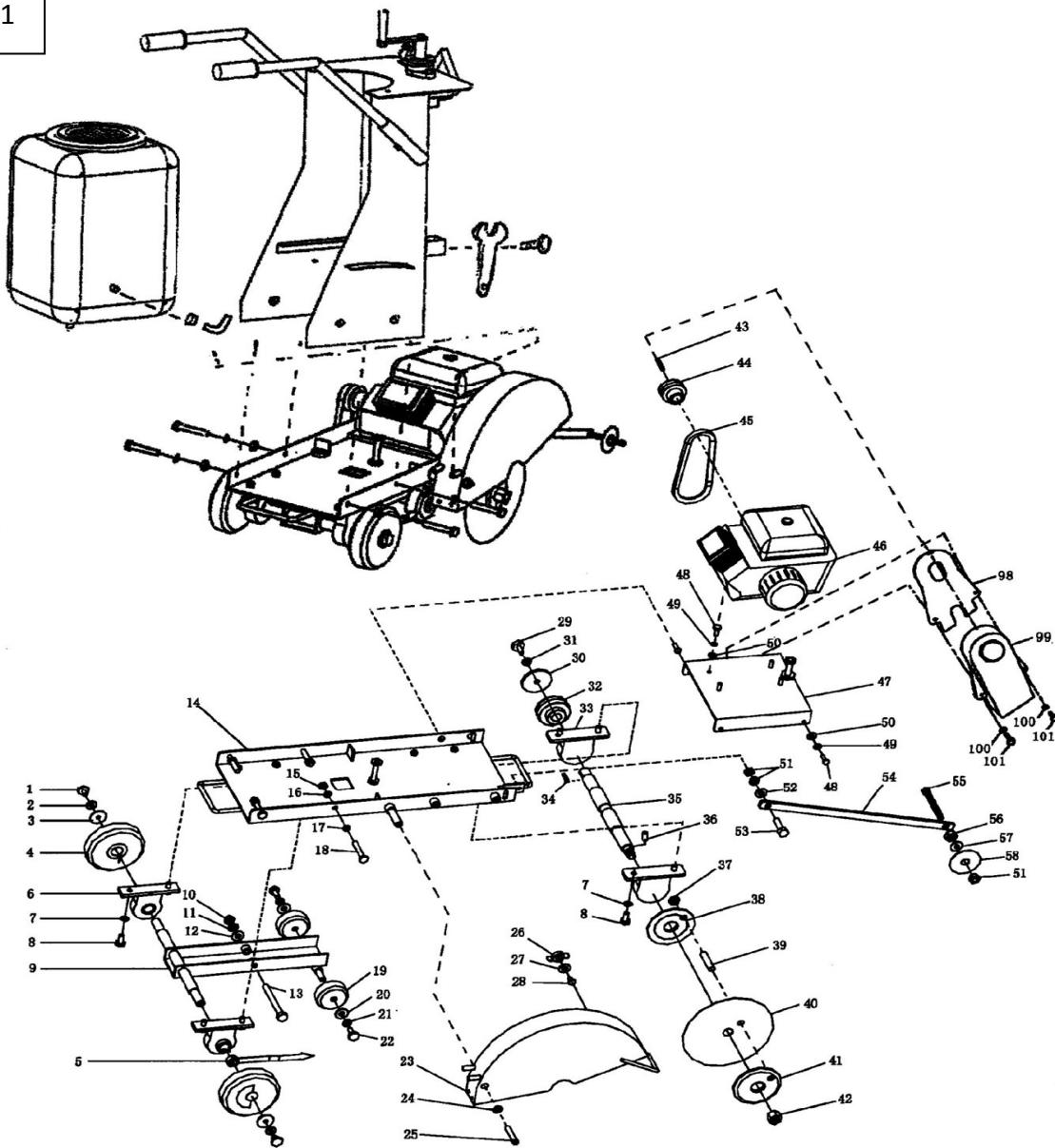
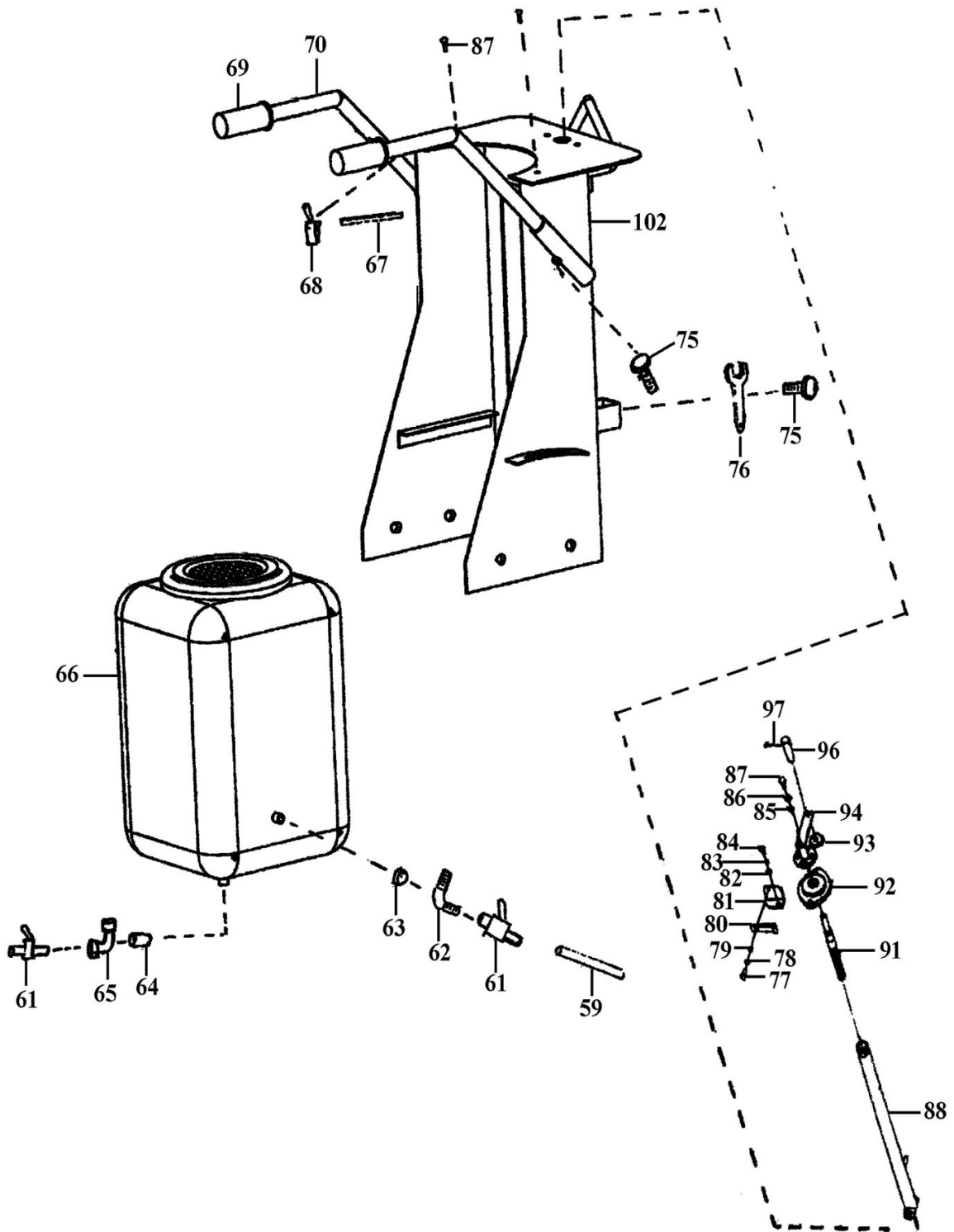

Fig. 2



Nº	Código	Descripción	Uds.	P.V.P.	Nº	Código	Descripción	Uds.	P.V.P.
Fig. 1									
6	5794006	Cjto..Soporte Rueda Exterior	2		39	5794039	Pasador M-8	1	
23	5794023	Carcasa Disco	1		41	5794041	Arandela Exterior	1	
30	5794030	Cjo. Arandela	1		42	5794042	Tuerca	1	
32	5794032	Polea	1		43	5794043	Chaveta	1	
33	5794033	Soporte Rueda	2		44	5794044	Polea Motor	1	
34	5794034	Chaveta	1		45	5794045	Correa	3	
35	5794035	Eje Ruedas	1						
36	5794036	Pasador M-6	1						
38	5794038	Arandela Interior	1						
Fig. 2									
61	5794061	Llave	2		94 96	5794096	Cjto. Manivela	1	
62	5794062	Codo M-M	1		*	5794098	Carcasa Interior Correas	1	
65	5794065	Codo M-H	1		*	5794099	Carcasa Exterior Correas	1	
66	5794079	Cjto Depósito	1		*	5794100	Cjto. Interruptor	1	
67	5794067	Cable Acelerador	1		*	5794004	Cjto Rueda Exterior	2	
68	5794068	Acelerador	1		*	5794019	Cjto. Rueda Interior	2	
69	5794075	Pomo	2						
70	5794070	Manillar	2						
91	5794091	Eje Engranaje	1						
92	5794103	Soporte Rod.	1						

NOTA: En ésta lista sólo están los recambios más habituales. Si se necesita algún otro “consultar”.